

B2scan 5030B

X-ray inspection machine B2scan 5030B is an advanced dual-energy X-ray inspection of hand luggage. With tunnel dimensions of 505 mm x 320 mm (W x H) it is ideal for inspection of hand luggage in hotels, ships, museums, offices, etc.

Along with unmatched ergonomics, reliability and safety, **B2scan 5030B** introscope provides excellent image quality and improved material classification. Introscope **B2scan 5030B** has the function of automatic detection of explosives and drugs.

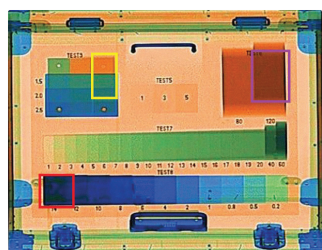

Automatic detection of explosives / drugs and alerts



Improved classification of materials: orange – organic, blue – metals, green – mixed materials

Technological peculiarities

- High image quality with 40 AWG wire resolution and the penetrating power of steel 18 mm.
- The X-ray dose rate around the equipment is close to the natural background level, which corresponds to all applicable international health standards and occupational safety.
- Automatic detection of explosives /drugs.
- TIP (projection of the image of dangerous objects) is a very effective way to train operators and control their work.
- Functional stepwise, continuous and local scaling provides convenient and quick magnification of the resulting image.
- The resulting images can be saved in common formats (BMP, JPG, PNG) and transfer to an external USB drive.
- The ergonomic design of the keyboard and user interface ensures effective and professional work of X-ray television introscope.
- The modular design, combined with built-in diagnostics, ensures efficient maintenance of the equipment.
- Data transmission over a local network using the TCP / IP family of protocols.
- Information exchange with the system of collecting results of technical monitoring and control using a unified data transfer protocol and an XML-based metadata.

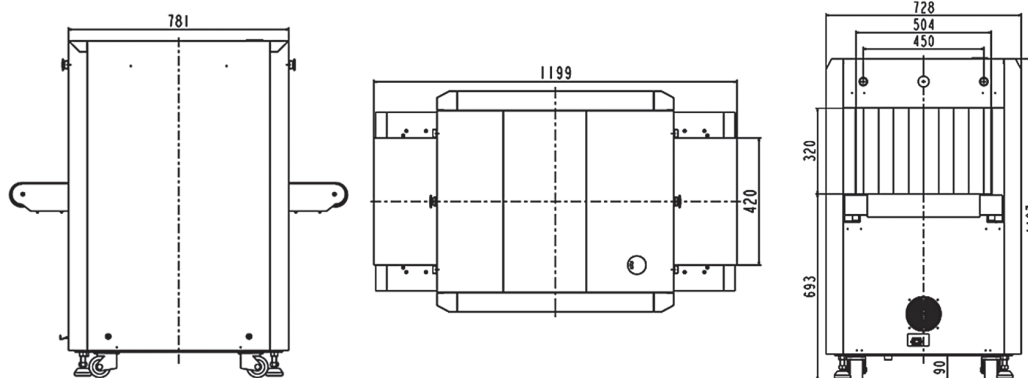

Equipment drawing

General specifications		Operating characteristic	
Tunnel dimensions	505 mm (W) x 320 mm (H)	Wire Resolution	40 AWG / 0,0787 mm
Conveyor speed	0,2 m/s	Steel penetration	18 mm
Conveyor height	695 mm	X-ray dose during the inspection	less than 2,5 mSv
Maximum load capacity	100 kg with an even distribution	Monitor	LCD, 21.5 inches, high resolution 1920x1080
Anode voltage	100 kV		
Image processing system		Health and safety	
Image processing functions	Color / BW image, organic / inorganic removal, change in absorption level, super-enhancement, negative image, high / low penetration, pseudocolor, etc.	X-ray dose rate	Less than 1 mSv /h (5 cm from the body) meets all applicable international standards
Material classification (by color)	Organic: orange, inorganic: blue, mixtures and light metals: green	Safety for photographic films	Guaranteed for highly sensitive film up to ASA/ISO 1600 (33 DIN)
Scaling	Selectable image scaling areas, magnification 1 ~ 64 times	Installation data	
Image return	Viewing previous images	Dimensions/weight	1200 mm (L) x 728 mm (W) x 1200 mm (H) / 300 kg
Memory capacity	Up to 100 000 images	Storage temperature	-40°C~+60°C
Additional functions	Date / time display, baggage counter, transaction log, user management, System-on/X-ray-on timers / Power-on self-test, built-in diagnostics tools, bi-directional scanning, image recognition training	Operating temperature range	0°C~+40°C
		Humidity	5%~95% non-condensing
		Power supplies	AC power 220B (-15%~+10%), 50 Hz / 60 Hz ± 3 Hz
		Power consumption	0.5 kVA