

B2scan 10080T

X-ray inspection machine B2scan 10080T is an advanced dual-energy X-ray inspection of hand luggage, baggage and cargo. Being equipping with two X-ray generators it provides a viewing of the checked object in two projections. With tunnel dimensions of 1010 mm x 805 mm (W xH) it is ideal for inspection of hand Luggage, Luggage and cargo at airports, railway stations, customs posts, ports, etc.

Along with unmatched ergonomics, reliability and safety, X-ray inspection machine **B2scan 10080T** provide excellent image quality and improved material classification. X-ray inspection machine **B2scan 10080T** provides excellent image quality and improved material classification.

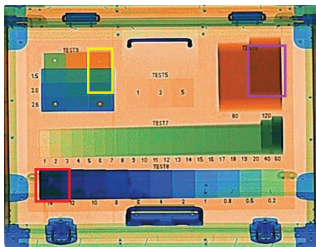

Automatic detection of explosives / drugs and alerts



Improved classification of materials: orange – organic, blue – metals, green – mixed materials

Technological peculiarities

- High image quality with 40 AWG wire resolution and the penetrating power of steel is 34 mm.
- The X-ray dose rate around the equipment is close to the natural background level, which corresponds to all applicable international health standards and occupational safety.
- Automatic detection of explosives / drugs.
- TIP (projection of the image of dangerous objects) is a very effective way to train operators and control their work.
- Functional stepwise, continuous and local scaling provides convenient and quick magnification of the resulting image.
- The resulting images can be saved in common formats (BMP, JPG, PNG) and transfer to an external USB drive.
- The ergonomic design of the keyboard and user interface ensures effective and professional work of X-ray television introscope.
- The modular design, combined with built-in diagnostics, ensures efficient maintenance of the equipment.
- Data transmission over a local network using the TCP / IP family of protocols.
- Information exchange with the system of collecting results of technical monitoring and control using a unified data transfer protocol and an XML-based metadata.

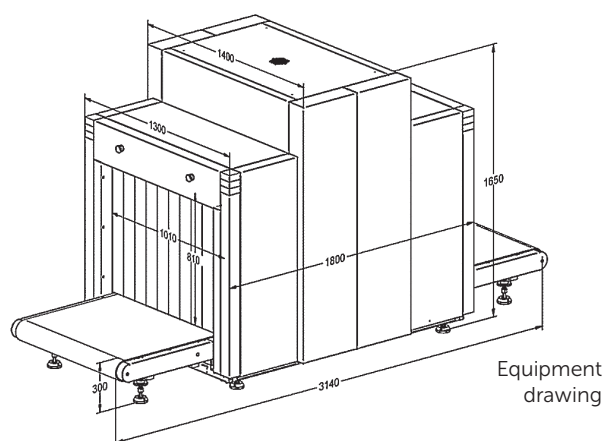

General specifications		Operating characteristic	
Tunnel dimensions	1010mm (W) x 805mm (H)	Wire Resolution	40 AWG / 0,08mm
Conveyor speed	0,2 m/c	Steel penetration	34 mm
Conveyor height	300 mm	X-ray dose during the inspection	less than 2 mSv
Maximum load capacity	200 kg with an even distribution	Monitor	LCD, 21.5 inches, high resolution 1920x1080
Image processing system		Health and safety	
Image processing functions	Color / BW image, organic / inorganic removal, change in absorption level, super-enhancement, negative image, high / low penetration, pseudocolor, etc.	Image processing functions	Color / BW image, organic / inorganic removal, change in absorption level, super-enhancement, negative image, high / low penetration, pseudocolor, etc.
Material classification (by color)	Organic: orange, inorganic: blue, mixtures and light metals: green	Safety for photographic films	Guaranteed for highly sensitive film up to ASA/ISO 1600 (33 DIN)
Scaling	Selectable image scaling areas, magnification 1 ~ 64 times	Installation data	
Image return	Viewing previous images	Dimensions/weight	3140 mm (L) x 1400 mm (W) x 1650 mm(H) / 950 kg
Memory capacity	Up to 100 000 images	Storage temperature	-40°C~+60°C
Additional functions	Date / time display, baggage counter, transaction log, user management, System-on/X-ray-on timers / Power-on self-test, built-in diagnostics tools, bi-directional scanning, image recognition training	Operating temperature range	0°C~+40°C
		Humidity	5%~95% non-condensing
		Power supplies	AC power 220B(15%~+10%) 50 Hz / 60 Hz ± 3 Hz
		Power consumption	1,0 kVA