

# B2scan 5030T

**X-ray inspection machine B2scan 5030T** is an advanced dual-energy X-ray inspection of hand luggage. With tunnel dimensions of 550 mm x 330 mm (W x H) it is ideal for screening hand luggage in hotels, ships, museums, offices, etc.

Along with unmatched ergonomics, reliability and safety, X-ray inspection machines **B2scan 5030T** provide excellent image quality and improved material classification.

X-ray inspection machine **B2scan 5030T** has the function of automatic detection of explosives and drugs.

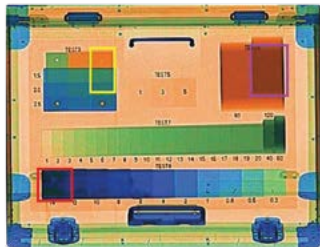

Automatic detection of explosives / drugs and alerts



Improved classification of materials: orange – organic, blue – metals, green – mixed materials

## Technological features

- High image quality with 40 AWG wire resolution and 14 mm steel penetration
- The X-ray dose rate around the equipment is close to the natural background level, which corresponds to all applicable international health standards and occupational safety
- Automatic detection of explosives / drugs
- TIP (projection of the image of dangerous objects) is a very effective way to train operators and control their work
- Functional stepwise, continuous and local scaling provides convenient and quick magnification of the received image
- Received images can be saved in common formats (BMP, JPG, PNG) and transfer to an external USB drive
- The ergonomic design of the keyboard and user interface ensures effective and professional work of X-ray television system
- The modular design, combined with built-in diagnostics, ensures efficient maintenance of the equipment
- Data transmission over a local network using TCP / IP protocols
- Information exchange with the system of technical monitoring results collection and control using a unified data transfer protocol and XML-based metadata format.

The equipment has passed compulsory and voluntary certification applicable on the Russian Federation territory. Technical parameters and complete set of goods are subject to change without notice.



[www.b2scan.ru](http://www.b2scan.ru)

+7 (495) 181 7757 | [info@b2scan.ru](mailto:info@b2scan.ru) |

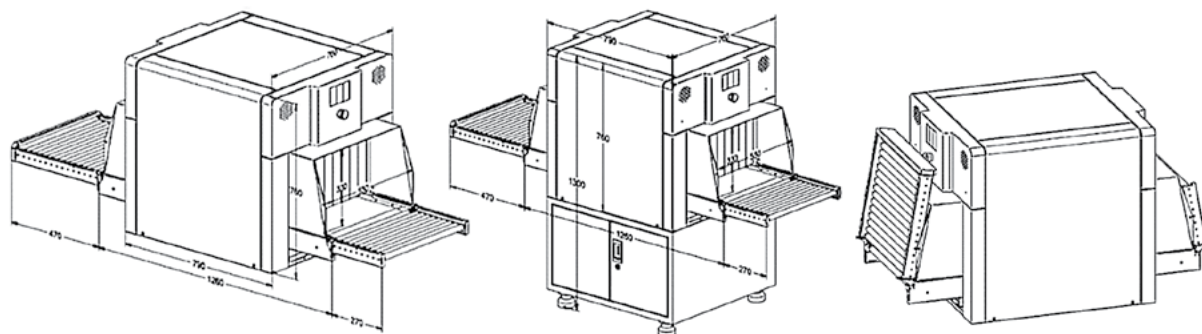

Equipment drawing

General specifications		Operating characteristics	
Tunnel dimensions	550 mm (W) x 330 mm (H)	Wire resolution	40 AWG / 0,0787 mm
Conveyor speed	0,2 m/s	Steel penetration	14 mm
Conveyor height	160 mm / 800 mm (with a pedestal)	X-ray dose during the inspection	less than 1m3v
Maximum load capacity	120 kg with an even distribution	Monitor	LCD, 21.5 inches, high resolution 1920x1080
Image processing system		Health and safety	
Image processing functions	Color / BW image, organic / inorganic removal, change in absorption level, super-enhancement, negative image, high / low penetration, pseudocolor, etc.	X-ray dose rate	Less than 1m3v/h (5 cm from the body) meets all applicable international standards
Material classification (by color)	Organic: orange, inorganic: blue, mixtures and light metals: green	Safety for photographic films	Guaranteed for highly sensitive film up to ASA/ISO 1600 (33 DIN)
Scaling	Selectable image scaling areas, magnification 1 ~ 64 times	Installation data	
Image return	Viewing previous images	Dimensions / weight	1260 mm (L) x 760 mm (W) x 760 mm (H) / 160 kg 1800 mm (L) x 760 mm (W) x 1300 mm (H) / 210 kg
Memory capacity	Up to 100 000 images	Storage temperature	-40 °C~+60 °C
Additional functions	Date / time display, baggage counter, transaction log, user management, X-ray television system / X-ray generator operating time counters, power-on self-test, built-in diagnostics tools, bi-directional scanning, image recognition training	Operating temperature range	0 °C~+40 °C
		Humidity	5%~95% non-condensing
		Power supplies	AC power 220V (15%~+10%) 50 Hz / 60 Hz ± 3 Hz
		Power consumption	0,6 kVA